

Instructions for Use

Vivacell[®] 100



85030-519-49



SARTORIUS

Contents

1	Vivacell® 100	4
1.1	Centrifuge	5
1.2	Pressure.....	5
1.3	Pressure-shake.....	5
1.4	Centrifugal Operation	6
1.5	Pressurized Bench Top Operation	7
1.6	Pressurized Operation on Laboratory Shaker	7
1.7	Equipment Required.....	7
1.8	Optional Equipment	7
1.9	Operation.....	8
2	Usage Tips	9
2.1	Flow Rate	9
2.2	Prerinsing	9
2.3	Sterilisation.....	9
2.4	Desalting or Solvent Exchange.....	10
2.5	Cleaning and Sanitising	10
2.6	Storage.....	10
3	Performance Characteristics	11
4	Chemical Compatibility	12
5	Ordering Information	14

1 Vivacell® 100

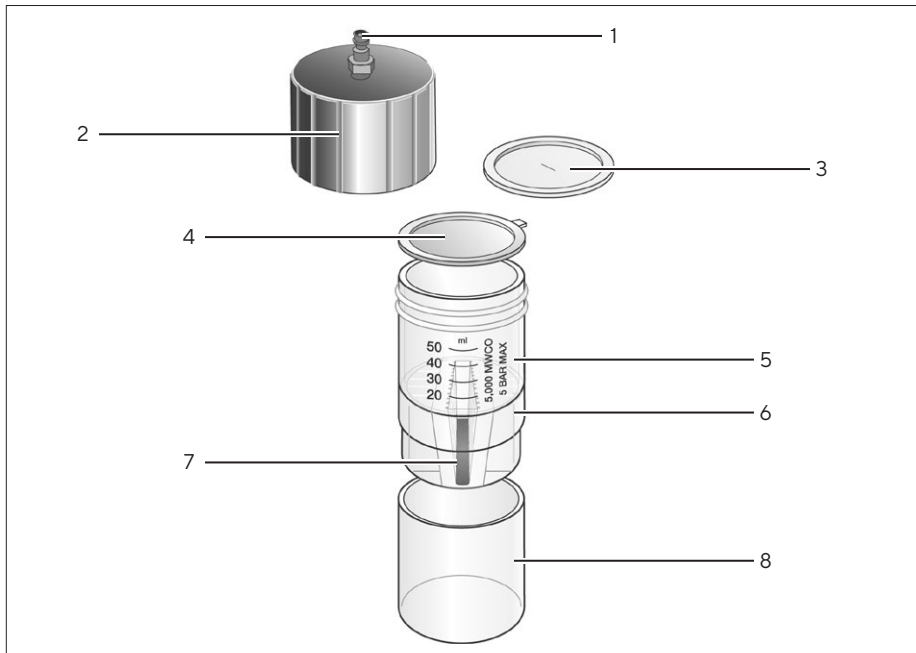

Pos.	Description
------	-------------

1	Quick release connector
---	-------------------------

2	Pressure head
---	---------------

3	TPE-V seal
---	------------

4	Concentrator cap
---	------------------

5	Graduations
---	-------------

6	Concentrator
---	--------------

7	Twin vertical membranes
---	-------------------------

8	Filtrate container fits standard 250 ml rotors
---	--

The Vivacell® 100, when used as a centrifugal device, fits only into swing bucket rotors accepting 250 ml bottles. The Vivacell® 100 can not be used in a fixed angle rotor. Vivacell® 100 units can also be used for single or extremely sensitive samples in the pressurized mode only and left on the bench or placed on a laboratory shaker for faster concentration. It can also be kept in a pressurized mode in the refrigerator. Handling is made easy by use of quick connectors. In whichever mode Vivacell® 100 is used, the vertical membrane design inhibits membrane fouling while the built-in dead stop impedes concentration to dryness and loss of sample.

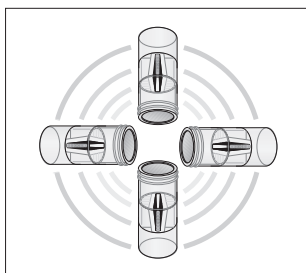

1.1 Centrifuge

- Process convenience
- Low shear, no foaming
- Less visual control

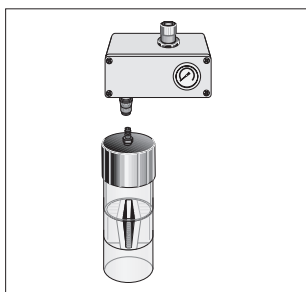

1.2 Pressure

- Simplicity and highest process control
- Ideal for refrigerated use
- Slower concentrations

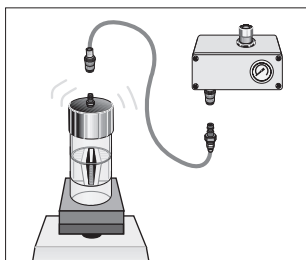

1.3 Pressure-shake

- Speed and process control
- Ideal for single samples

Vivacell® 100 Specifications

Without pressure head (Ø × L)	62 × 123 mm
With pressure head (Ø × L)	71 × 197 mm
Max pressure	5 bar (75 psi)
Active membrane area	23.5 cm ²
Hold-up vol. memb. & support	< 250 µl
Dead stop volume	350 µl

Vivacell® 100 Materials of construction

Pressure head	Acetal
Quick release connector	Acetal
Concentrator cap (centrifugal)	Polypropylene
Concentrator filtrate container	Polycarbonate
Pressure head seal	Thermoplastic Elastomer Vulcanizate

1.4 Centrifugal Operation

The Vivacell® 100 can be used in any centrifuge accepting 250 ml bottles. At 2,000 xg and typically in less than 25 minutes a 90 ml samples will be concentrated 30 times, while the built in dead stop impedes concentration to dryness.

1.5 Pressurized Bench Top Operation

The Vivacell® 100 can be pressurized and left to concentrate standing on a bench top, or in a refrigerator for maximum process control with minimum equipment requirements.

1.6 Pressurized Operation on Laboratory Shaker

Single samples of up to 90 ml can be processed just as simply by using the Vivacell® 100 Pressure Head and an orbital laboratory shaker. Assembly just takes a few seconds, whilst a single pressure charge is sufficient to reduce 90 ml to less than 3 ml in typically less than 30 minutes.

1.7 Equipment Required

A. For use with Centrifuge

1. Centrifuge with swing bucket
2. Pasteur or fixed volume pipettes for sample recovery

B. For use with Gas Pressure

1. Vivacell® 100 Pressure Head (Product No. VCA800)
2. Air Pressure Controller (Product No. VCA002) or equivalent pressure regulator
3. Pasteur or fixed volume pipettes for sample recovery

1.8 Optional Equipment

Laboratory orbital shaker accepting 250 ml bottles.

1.9 Operation

1. Select the most appropriate membrane cut-off for your sample.
For maximum recovery select a MWCO at least 50% smaller than the molecular weight of your target molecule.
2. Fill concentrator with 20 – 100 ml of sample solution.

A. Centrifuge

3. Cap concentrator with concentrator cap (polypropylene).
4. Insert assembled concentrator into the swing bucket of the centrifuge.
5. Once the desired concentration is achieved (see table 3 for guide on concentration times), remove assembly and recover sample from the bottom of the concentrate pocket with a pipette.

B. Using Gas Pressure

3. Seal concentrator with TPE-V seal and attach Pressure Head (VCA700) to concentrator assembly. Hand tighten to ensure an air tight seal.
4. Set APC regulator to desired pressure (a pressure release valve factory set at 5 bar does not allow operation above this pressure). Lift regulator knob to unlock and turn in the appropriate direction (4 bar is recommended for most applications). Attach assembly to the female coupling to charge the Pressure Head. Detach from coupling by raising the outer locking sheath. One charge is normally sufficient to fully concentrate the sample.
5. Optional: It is possible to use the concentrator assembly under constant pressure by attaching a female coupling (Prod. No. VCA010), to the extension line from the APC then attaching this female coupling to the Pressure Head as in 4.
6. Leave to concentrate. For faster processing place on laboratory shaker and agitate gently at approximately 200 – 300 revs. per minute. Avoid high speed shaking as this is unnecessary and can cause foaming.
7. Once desired concentration level has been reached (see table 3 for guide on concentration times) remove assembly and de-pressurize by unscrewing Pressure Head or by releasing air from the center of the inlet valve with a pointed instrument.

8. For maximum recovery, allow to stand after de-pressurization for 10 – 15 minutes and then extract concentrate using a Pasteur or fixed volume pipette.

2 Usage Tips

2.1 Flow Rate

Filtration rate is affected by several parameters, including membrane cut-off, sample concentration, viscosity, centrifugal force, pressure and temperature. Expect significantly longer spin times for starting solutions with over 5% solids. When operating at 4°C, flow rates are approximately 1.5 times slower than at 25°C. Viscous solutions such as 50% glycerine will take up to 5 times longer to concentrate than samples in a predominantly buffer solution.

2.2 Prerinsing

Membranes fitted to Vivacell® concentrators contain trace amounts of Glycerine. Should this interfere with analysis this can be removed by rinsing approximately 50 ml of buffer solution or deionised water through the concentrator. Decant filtrate and concentrate before processing sample solution.

2.3 Sterilisation

Vivacell® concentrators are not autoclaveable. To sterilise, use a 70% ethanol solution or sterilising gas mixture.

2.4 Desalting or Solvent Exchange

The sample is first concentrated to desired level. Filtrate is discarded, then the device is refilled with an appropriate solvent. The sample is concentrated again and the process repeated until the concentration of the contaminating microsolite is sufficiently reduced. Typically three wash cycles will remove 99% of initial salt content.

2.5 Cleaning and Sanitising

Vivacell® concentrators may be used several times if recommended cleaning and storage instructions are adhered to, and the membrane is not allowed to dry.

1. Rinse out the device several times with deionized water.
2. Fill the concentrator with a solution of 60% Ethanol and 40% 1M HCl. Alternatively fill concentrator with a dilute non ionic surfactant. Place the device in filtrate bottle and allow to soak for 1 – 2 hours. For best results, agitate on a laboratory shaker for approximately 30 minutes.

WARNING

Strong alkaline solutions should not be used.

3. Rinse thoroughly with clean water before re-use or storage.

2.6 Storage

Following cleaning Vivacell® devices may be stored for several weeks in a 20% Ethanol solution. For best results, fill filtrate bottle with approximately 100 ml of solution, place concentrator in the bottle and then add a further 50 ml to the concentrator. This procedure will ensure that the membrane remains wetted throughout storage. Close with cap provided and preferably keep refrigerated.

3 Performance Characteristics

Typical performance	Time to concentrate 30x min. at 20°C			Solute
90 ml Start volume	In centrifuge 2,000 g	As pressure cell 4 bar (58 psi) pressure		recovery %
	Swing out rotor	No agitation	Orbital shake	
BSA 1.0 mg/ml (66,000 MW)				
5,000 MWCO PES	22	75	25	96%
10,000 MWCO PES	16	60	20	96%
30,000 MWCO PES	16	60	20	94%
IgG 0.25 mg/ml (160,000 MW)				
50,000 MWCO PES	20	70	30	94%
100,000 MWCO PES	20	85	30	90%
Latex beads 0.004% in DMEM + 10% FCS (0.055 µm)				
300,000 MWCO PES	35	-	120	99%
Latex beads 0.004% in DMEM + 10% FCS (0.24 µm)				
1,000,000 MWCO* PES	4	5	4	99%

* 2,000 g in centrifuge, 2 bar (29 psi) pressure

4 Chemical Compatibility

	Vivacell® 100
Solution	
Acetic Acid (25.0%)	OK
Acetone (10.0%)	NO
Acetonitrile (10.0%)	OK
Ammonium Hydroxide (5.0%)	?
Ammonium Sulphate (sat)	OK
Butanol (70%)	OK
Chloroform (1.0%)	NO
Dimethyl Formamide (10.0%)	NO
Dimethyl Sulfoxide (5.0%)	OK
Ethanol (70.0%)	OK
Ethyl Acetate	NO
Formaldehyde (30%)	OK
Formic Acid (5.0%)	OK
Guanidine HCl (6 M)	OK
Hydrocarbons, aromatic	NO
Hydrocarbons, chlorinated	NO
Hydrochloric Acid (1 N)	OK
Imidazole (50 mM) (2 hr contact time)	NO
Lactic Acid (50.0%)	OK
Mercaptoethanol (10 mM)	OK

Methanol (60%)	OK
Nitric Acid (10.0%)	OK
Phenol (1.0%)	OK
Phosphate Buffer (1.0 M)	OK
Polyethylene Glycol	OK
Pyridine	NO
Propanol 70%	OK
Sodium Carbonate (20%)	OK
Sodium Deoxycholate (5.0%)	?
Sodium Dodecylsulfate (0.01 M)	OK
Sodium Hydroxide	NO
Sodium Hypochlorite (200 PPM)	NO
Sodium Nitrate (1.0%)	OK
Sulfamic Acid (3.0%)	OK
Tetrahydrofuran (5.0%)	NO
Toluene (1.0%)	NO
Trifluoroacetic Acid (10%)	OK
Tween* 20 (0.1%)	OK
Triton** X-100 (0.001 M) (0.06%)	OK
Urea (8 M)	OK

OK = Acceptable

? = Questionable

NO = Not recommended

* Tween® is a registered trademark of ICI Americas Inc.

** Triton® is a registered trademark of Union Carbide Corp.

5 Ordering Information

Vivacell® 100 Polyethersulfone with Polypropylene concentrator cap	Pack size	Prod. no.
5,000 MWCO	2	VC1011
5,000 MWCO	10	VC1012
10,000 MWCO	2	VC1001
10,000 MWCO	10	VC1002
30,000 MWCO	2	VC1021
30,000 MWCO	10	VC1022
50,000 MWCO	2	VC1031
50,000 MWCO	10	VC1032
100,000 MWCO	2	VC1041
100,000 MWCO	10	VC1042
300,000 MWCO	2	VC1051
300,000 MWCO	10	VC1052
1,000,000 MWCO	2	VC1061
1,000,000 MWCO	10	VC1062
0.2 µm	2	VC1071
0.2 µm	10	VC1072

Accessories	Pack size	Prod. no.
Air pressure controller (APC) complete with pressure gauge, regulator, over-pressure safety valve, female connector, 1 m extension line (4 mm pressure tubing) with male and female connectors and 1 m of 6 mm inlet tubing	1	VCA002
Plastic pipettes	100	VPA005
Female connector	1	VCA010
Male connector	1	VCA011
4 mm pressure tubing (3 m)	1	VCA012
TPE-V replacement seals	10	VCA014
Vivacell® 100 pressure head with replacement seals (5)	1	VCA800

Sartorius Stedim Lab Ltd.
Sperry Way, Stonehouse Park
GL10 3UT Stonehouse, Gloucestershire, UK

Phone: +44 1453 821972
www.sartorius.com

The information and figures contained in these instructions correspond to the version date specified below.

Sartorius reserves the right to make changes to the technology, features, specifications and design of the equipment without notice.

Masculine or feminine forms are used to facilitate legibility in these instructions and always simultaneously denote the other gender as well.

Copyright notice:

This instruction manual, including all of its components, is protected by copyright.

Any use beyond the limits of the copyright law is not permitted without our approval.

This applies in particular to reprinting, translation and editing irrespective of the type of media used.

Last updated:
06 | 2021

© 2021 Sartorius Stedim Lab Ltd.
Sperry Way, Stonehouse Park
GL10 3UT Stonehouse, Gloucestershire, UK

AM | Publication No.: SLU6100-e210610